



T-CONNECTORS AND END CONNECTORS



Material:

T-connector 30x30 / end connector 45x45: die-cast aluminium

T-connector 45x45: die-cast zinc

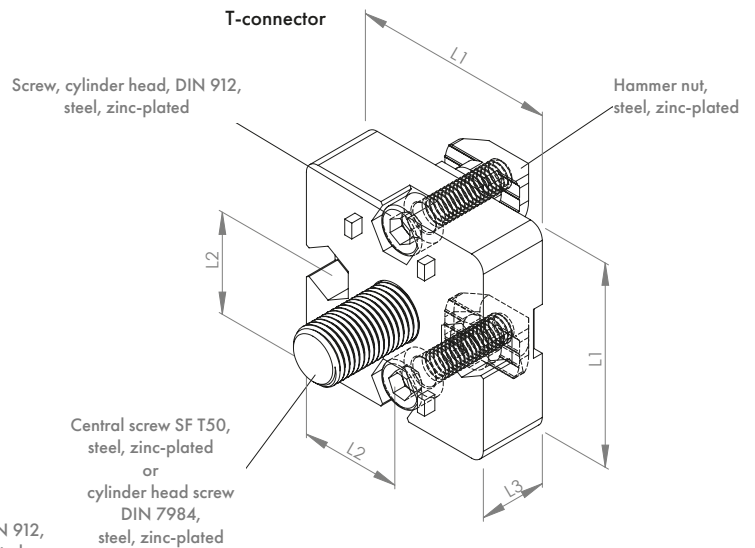
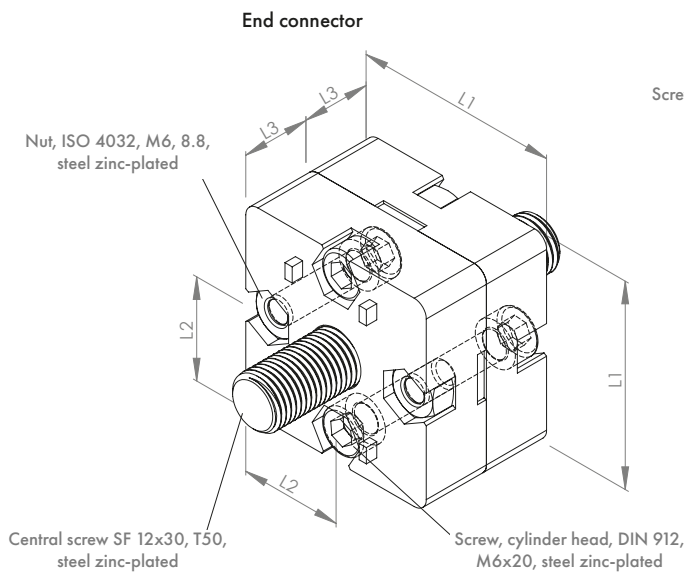
For connecting two profiles at a 90° angle. (T-connector) Or for connecting two profiles end to end. (End connector) No profile processing actions are required to assemble the items thanks to the self-tapping screws (SF).



Description	L1 (mm)	L2 (mm)	L3 (mm)	Version	Weight (g)	ESD	Art. no.:
T-connector set 30x30	30	15	13	With fastening kit*	51.0		333010
T-connector set 45x45	45	22.5	15	With fastening kit**	166.0		333021
End connector set 45x45	45	22.5	15	With fastening kit***	34.0		333030

Fastening kit: *	Fastening kit: **	Fastening kit: ***
2x hammer nuts slot 8 M5 steel, zinc-plated	2x hammer nuts slot 10 M6, steel, zinc-plated	2x central screws SF 12x30 T50, steel, zinc-plated
2x screws, cylinder head, M5x16 DIN 912, 8.8, zinc-plated	1x central screw SF 12x30 T50, steel, zinc-plated	4x screws, cylinder head, DIN 912, M6x20, 8.8, steel, zinc-plated
1x screw, cylinder head, M8x20 DIN 7984, 8.8, zinc-plated	2x screws, cylinder head, DIN 912, M6x20, 8.8, steel, zinc-plated	4x nuts, ISO 4032, M6, 8.8, steel, zinc-plated