





## FORM CONNECTOR SET SLOT 8

The item is delivered partially pre-assembled.  
(Screw and sleeve are already connected)

For connecting two aluminium profiles at a 90° angle.

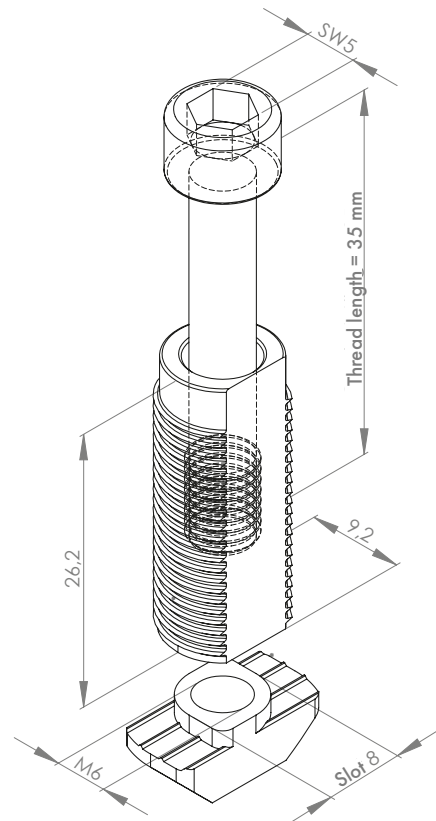
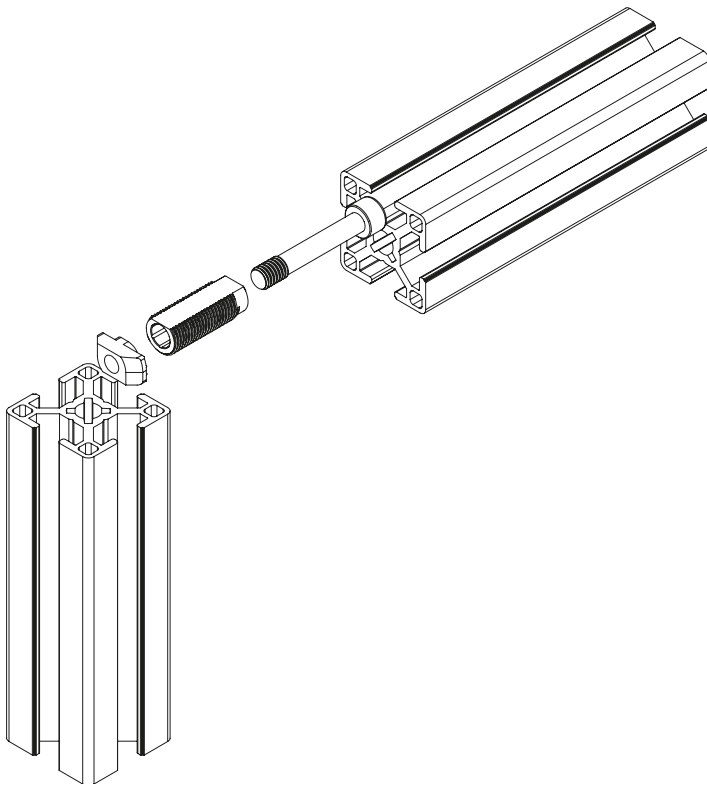
The connector sleeve is self-tapping - no preparatory profile processing is required.



Description	Length (mm)	Slot	Thread (M)	Version	Weight (g)	ESD	Art. no.:
Form connector set slot 8	26.2	8	M6	With fastening kit*	30.0		330120

### Fastening kit:\*

- 1x form connector slot 8, steel, zinc-plated
- 1x screw, cylinder head M6x35, steel, zinc-plated
- 1x hammer nut slot 8 M6, steel, zinc-plated