

FORM CONNECTOR SET SLOT 10 LIGHT 
FORM CONNECTOR SET SLOT 10 HEAVY

The item is delivered partially pre-assembled.
 (Screw and sleeve are already connected)

For connecting two aluminium profiles at a 90° angle.

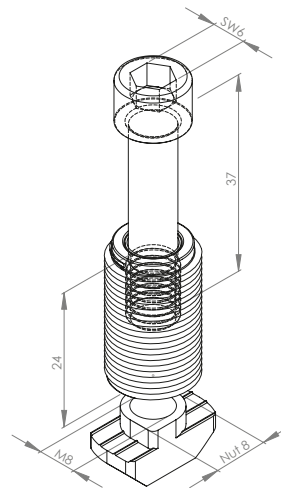
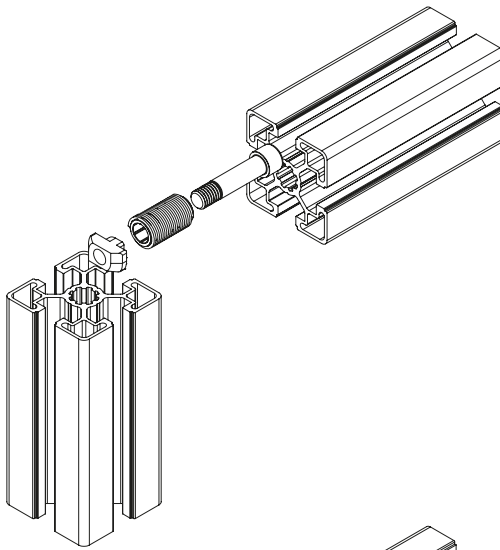

The connector sleeve is self-tapping - no preparatory profile processing is required.

330100

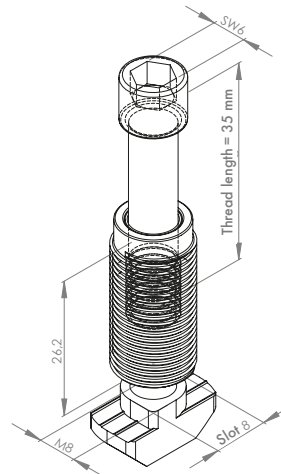
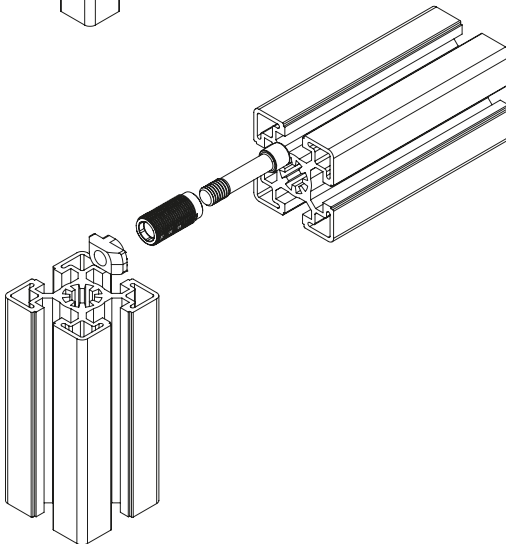

330110



Description	Length (mm)	Slot	Slot base (mm)	Thread (M)	Version	Weight (g)	ESD	Art. no.:
Form connector set slot 10 light	24	10	14.75	M8	With fastening kit*	37.0		330100
Form connector set slot 10 heavy	24	10	12.5 - 13	M8	With fastening kit**	37.0		330110

Fastening kit:*	Fastening kit:**
1x form connector slot 10 light, steel, zinc-plated	1x form connector slot 10 heavy, steel, zinc-plated
1x screw, cylinder head M8x37, steel, zinc-plated	1x screw, cylinder head M8x37, steel, zinc-plated
1x hammer nut slot 10 M8, steel, zinc-plated	1x hammer nut slot 10 M8, steel, zinc-plated