

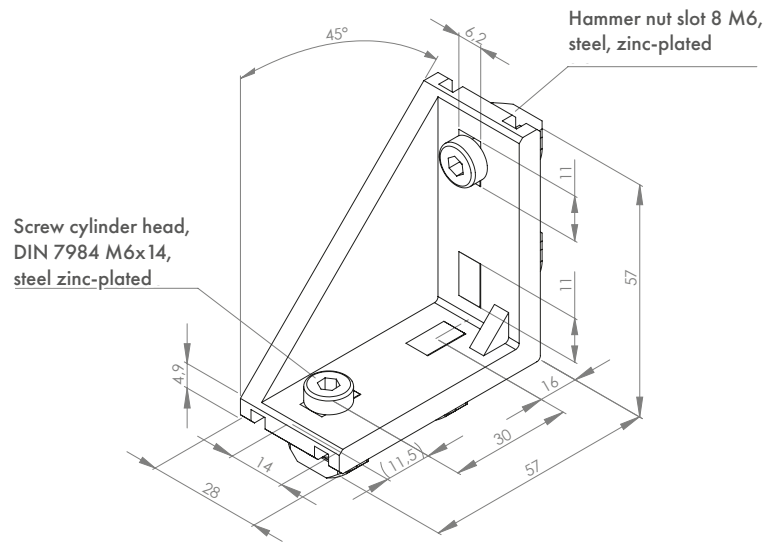
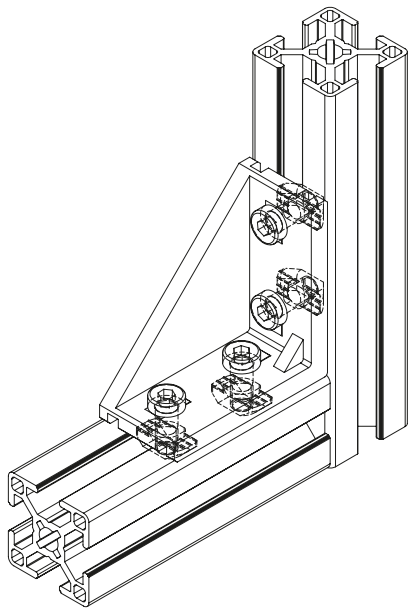

ANGLE BRACKET 30x60 SLOT 8

Angle bracket material: die-cast aluminium

For connecting two profiles at a 90° angle.

Mounting this item does not require any profile processing.



Description	Slot	Dimensions	Version	Weight (g)	ESD	Art. no.:
Angle bracket 30x60 slot 8	8	30x60	Without fastening kit	130.0		321042
Angle bracket 30x60 slot 8 with fastening kit *	8	30x60	With fastening kit*	153.0		321043

Fastening kit: *

4x screws, cylinder head, DIN 7984, M6x14, 8.8, steel, zinc-plated

4x hammer nuts slot 8 M6, steel, zinc-plated