

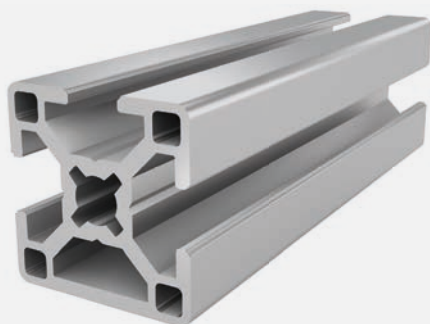

PROFILE 30x30 3N SLOT 8

Material: anodised aluminium



Technical data:

Surface A [cm ²]	3.32
Moment of inertia I _x [cm ⁴]	3.10
Moment of inertia I _y [cm ⁴]	2.78
Section modulus W _x [cm ³]	1.97
Section modulus W _y [cm ³]	1.85
Weight m [kg/m]	0.90

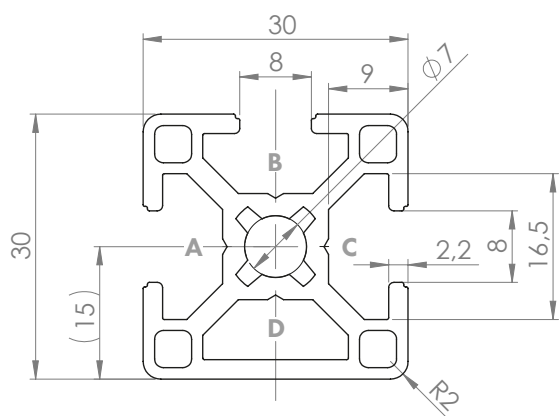

Standard processing:	Art. no.:
M8 / -	103200
M8 / M8	103205
D7.8 / -	102100
D7.8 / D7.8	102102
D7.8+ / D7.8+	102117
D11 / -	102400
D11 / D11	102405
D11 (SSV) / -	102370
D11 (SSV) / D11 (SSV)	102372
D11 (SSV) / D11 V (SSV)	102374

Explanations and further processing options can be found on p. 223-231

Dimensions (version)	Length (mm)	Slot	Weight (kg)	Art. no.:
30x30 3N	Cut to length	8	0.9 kg/m	20101030
30x30 3N	6060	8	0.9 kg/m	20101031

If this profile is cut to length, the cutting costs incurred per saw cut must be factored in. (Art. no.: 101010)

COVER CAP 30x30 SLOT 8, 30x30 WITH HOLE SLOT 8

Material: PA plastic

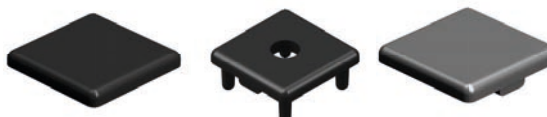

Dimensions (version)	Slot	Weight (g)	Version	Art. no.:
30x30	8	4	Black	401010
30x30	8	4	With hole (Ø8.5), black	401016
30x30	8	4	Signal grey	401110