

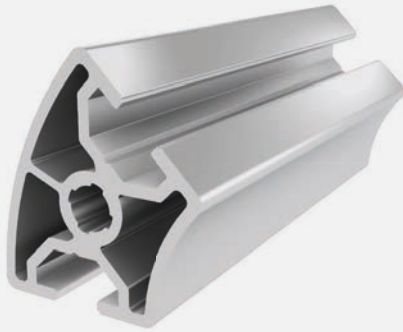

PROFILE 30 R30/R60 - 45° SLOT 8

Material: anodised aluminium



Technical data:

Surface A [cm ²]	4.12
Moment of inertia I _x [cm ⁴]	3.70
Moment of inertia I _y [cm ⁴]	5.29
Section modulus W _x [cm ³]	2.13
Section modulus W _y [cm ³]	2.37
Weight m [kg/m]	1.11

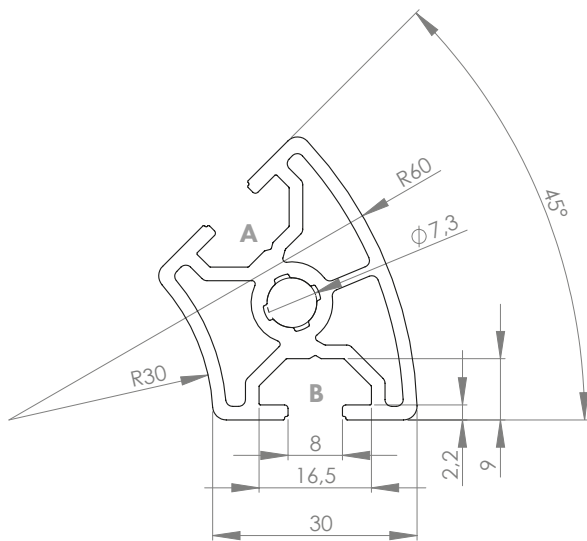

Standard processing:	Art. no.:
M8 / -	103200
M8 / M8	103205

Explanations and further processing options can be found on p. 223-231

Dimensions (version)	Length (mm)	Slot	Weight (kg)	Art. no.:
30 R30/R60 - 45°	Cut to length	8	1.11 kg/m	20101080
30 R30/R60 - 45°	6060	8	1.11 kg/m	20101081

If this profile is cut to length, the cutting costs incurred per saw cut must be factored in. (Art. no.: 101010)

COVER CAP

Material: PA plastic

Dimensions (version)	Slot	Weight (g)	Version	Art. no.:
-	-	-	-	-