



PROFILE 5 10x20

Material: anodised aluminium



Technical data:

Surface A [cm ²]	1.29
Moment of inertia I _x [cm ⁴]	0.12
Moment of inertia I _y [cm ⁴]	0.53
Section modulus W _x [cm ³]	0.22
Section modulus W _y [cm ³]	0.53
Weight m [kg/m]	0.22

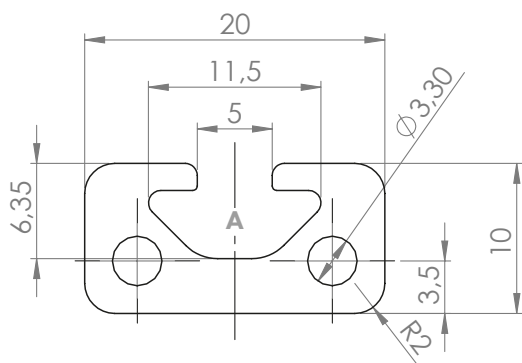

Standard processing:	Art. no.:
M5 / -	103170
M5 / M5	103171
M5= / -	103175
M5= / M5=	103172
D4.5 / -	102170
D4.5 / D4.5	102172

Explanations and further processing options can be found on p. 223-231

Dimensions (version)	Length (mm)	Slot	Weight (kg)	Art. no.:
10x20	Cut to length	5	0.22 kg/m	20200500
10x20	6060	5	0.22 kg/m	20200501

If this profile is cut to length, the cutting costs incurred per saw cut must be factored in. (Art. no.: 101010)

COVER CAP 5 10x20

Material: PA plastic



Dimensions (version)	Slot	Weight (g)	Version	Art. no.:
10x20	5	0.6	Black	421005