

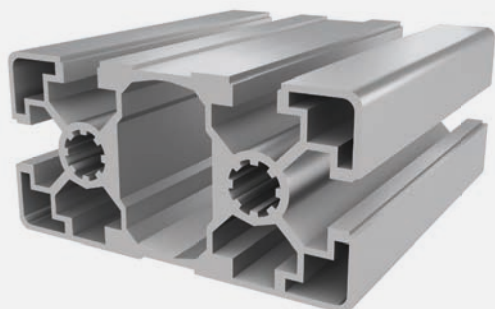

## PROFILE 45x90L 4N SLOT 10 (light)

Material: anodised aluminium



### Technical data:

Surface A [cm <sup>2</sup> ]	11.90
Moment of inertia I <sub>x</sub> [cm <sup>4</sup> ]	86.80
Moment of inertia I <sub>y</sub> [cm <sup>4</sup> ]	25.80
Section modulus W <sub>x</sub> [cm <sup>3</sup> ]	19.30
Section modulus W <sub>y</sub> [cm <sup>3</sup> ]	11.10
Weight m [kg/m]	3.20

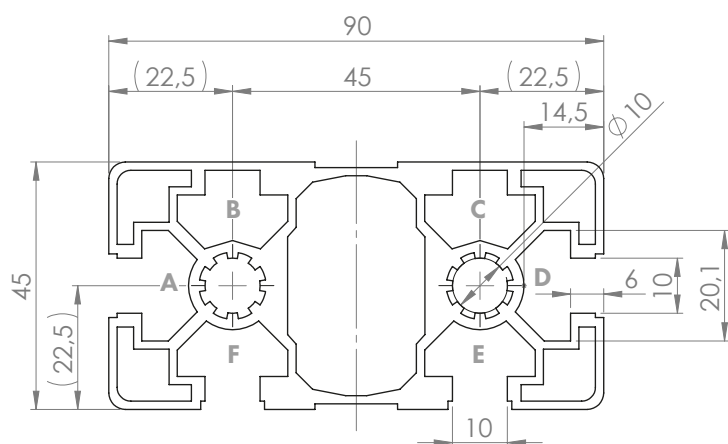

Standard processing:	Art. no.:
M12= / -	103315
M12= / M12=	103320
D9.8= / -	102340
D9.8= / D9.8=	102320
D9.8= / D9.8V	102330
D9.8V / D9.8V	102302
D17V / -	102510
D17V / D17V	102540

Explanations and further processing options can be found on p. 223-231

Dimensions (version)	Length (mm)	Slot	Weight (kg)	Art. no.:
45x90L 4N	Cut to length	10	3.1 kg/m	20106060
45x90L 4N	6060	10	3.1 kg/m	20106061

If this profile is cut to length, the cutting costs incurred per saw cut must be factored in. (Art. no.: 101020)

## COVER CAP 45x90 SLOT 10

Material: PA plastic



Dimensions (version)	Slot	Weight (g)	Version	Art. no.:
45x90	10	16	Black	401060
45x90	10	16	Signal grey	401160